

ECO LINE

Mini in-line pump (solenoid), ultra compact and easy to install, for the condensate removal of air conditioners up to 10kW / 36000BTU.

Ref: DE05SCC600



ECO

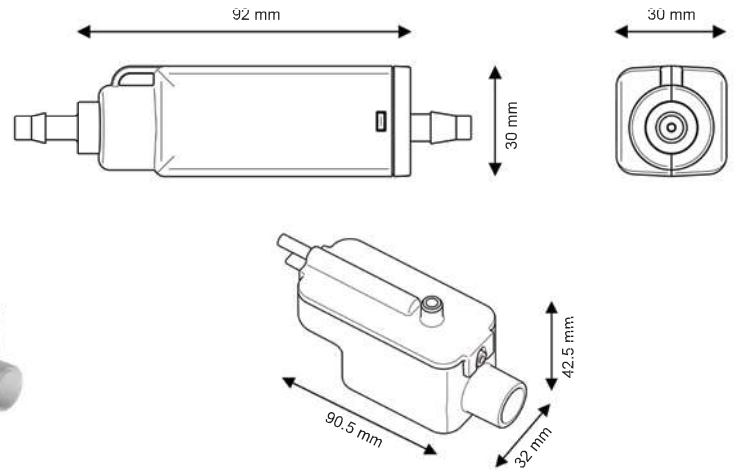
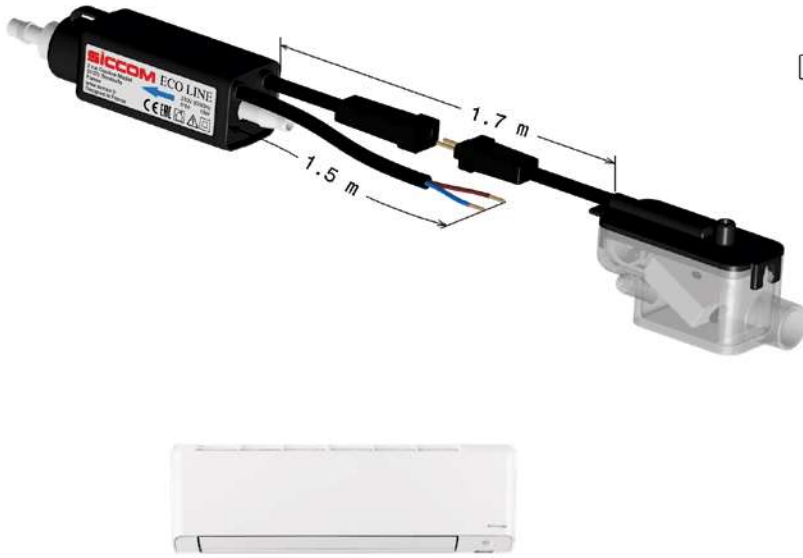

Hose diameter
Suction : 6/9 mm - not supplied
Discharge : 6/9 mm - not supplied

SPECIFICATIONS

Flowrate max	13.2 l/h
Suction head max	1.5 m
Discharge head max	10 m
Electrical power	19W
Voltage	220-240V 50/60Hz
Alarm*	No alarm
Noise level	
Protection rating	IP64
Thermal protection	Yes
Operating cycle**	100%
Power cable	1.5 m
Dimensions	92 x 30 x 30 mm / 90 x 32 x 42 mm
Certifications	CE, UKCA, EAC

* Alarm option available on request.
** The pump is able to run 100% of the time if necessary.

FLOWRATE

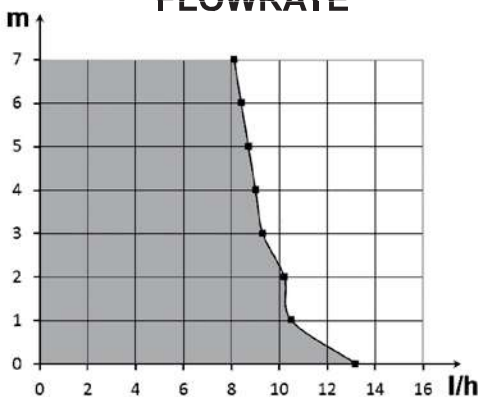

BENEFITS

ULTRA COMPACT pump

The most compact pump of the market!
Easy installation in a duct or inside the air conditioner.



IP64 protection

Protected against water splashes and dust.

Plug & Play connectors

Make installation and maintenance easier.



WATERPROOF removable reservoir

The reservoir, which can be removed for easy maintenance, now has a waterproof seal!



Hanging hook

This astucious hook allows to fix or hang the pump wherever you want (duct, false ceiling, inside de unit...).



Accessories included

All necessary accessories are included in the box.



CONTENTS

Pump - Reservoir - Double-side adhesive for reservoir fixing - Inlet tube - 3 clamps

